

Quad Lifter Series

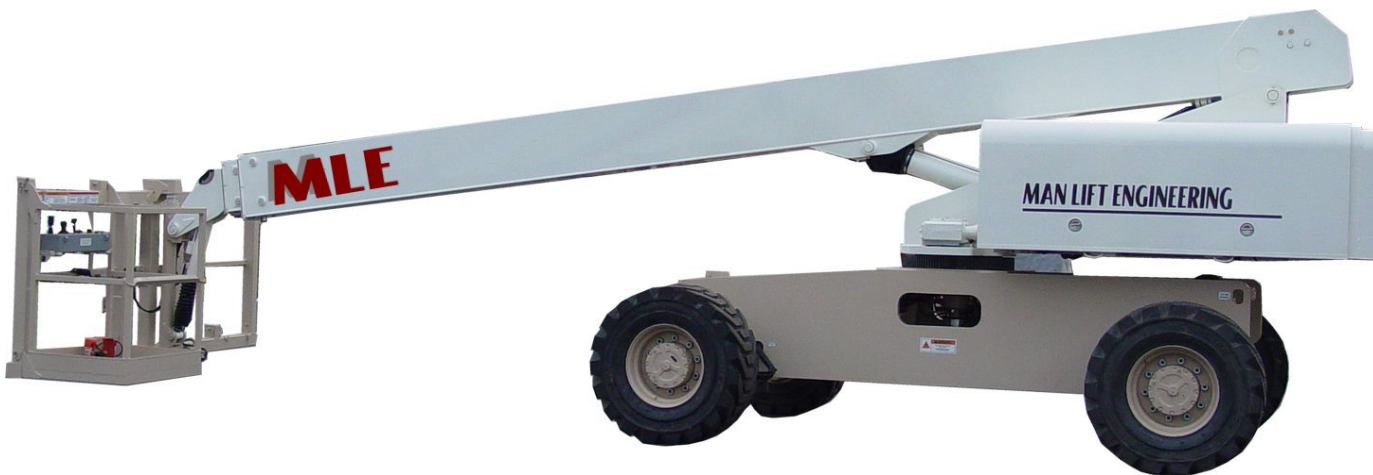

T80MH-1500

Man Lift – Forklift – Winch Lift – Material Lift

Standard Features

- Working Height 86-feet (24.38m)
- Platform Height 80-feet (26.21m)
- Stowed Height 9 ft 6 in (261.62cm)
- Stowed Length 37 ft 6 in (11.43m)
- 4 Wheel Drive
- Dual Fuel Engine
- 360° Continuous Rotation Boom
- Platform Size 96 x 36 in
- 160° Platform Rotation
- Hydrostatic Drive
- 2000-pound (907.184kg) Platform Capacity
- 110V Line to Platform
- Proportional Controls
- Platform Display
- Platform Load Sensing
- Self-Diagnostic Control System

Optional Equipment:

- Single 1,000-pound (453kg) Winch
- 1,500 lb Forks with one Man Basket
- 7500 Watt Generator
- Generator & Welder Package
- Foam Filled Tires
- Horn
- ½" Air Line to Platform
- Duetz Diesel Engine
- Strobe Light
- Platform Work Lights
- Air Compressor

US patents:

- Load Sensing Mechanism #US 7,004,285B2
- Material Handling Devise #US 7,182,173B2

MAN & MATERIAL LIFT ENGINEERING

Specifications

Specifications subject to change without prior notice

Load Range Diagram

T80MH-1500	US	Metric
Working Height	86 feet	26.2m
Platform Height	80 feet	24.4m
Platform Capacity	1500 lbs	680kg
Platform Size	96 X 36 in	2.4 X .9m
Stowed Height	9 ft 6 in	2.9m
Stowed Length	37 ft 6in	11.4m
Horizontal Reach	60 ft	18.3m
Overall Width (Drive Mode)	8 ft 6 in	2.6m
Overall Width (Lift Mode)	14 ft	4.3m
Tail Swing	3 ft 11 in	1.2m
Outside Turning Radius	19 ft 8 in	6.0m
Inside Turning Radius	8 ft 1 in	2.5m
Ground Clearance	10.5 in	.3m
Turret Rotation Cont	360°	360°
Platform Rotation	100°	100°
Engine Power	80hp	80hp
Hydraulic Tank Capacity	45 gal	170.3L
Fuel Tank Capacity	35 gal	132.5L
Wheel Base	10 ft	3.0m
Gross Weight	41,500 lbs	18,824.4kg
Travel Speed	3.5 MPH	3.5MPH
Gradeability (4WD)	30%	30%

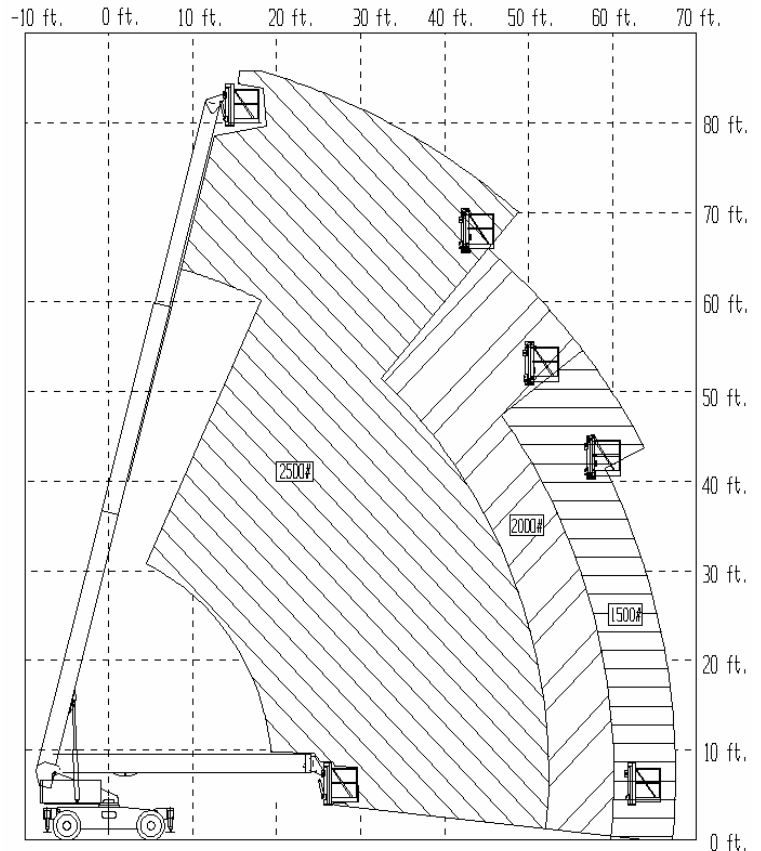

Special Features

Converts in Seconds – No tools are necessary to convert the Quad Lifter to one of the different lifting configurations.

Reduced Down Time – Quad Lifter does the work of 4 machines, reducing time on the job site by 1/3. One machine can lift man and material.

Lower Transport Costs – Ship one Quad Lifter on one truck. Quad Lifter and its attachments are light enough to fit on one truck as a legal load.

Q u a d L i f t e r T 8 0 M H - 1 5 0 0

MAN & MATERIAL LIFT ENGINEERING

5707 South Pennsylvania Avenue

Cudahy, WI 53110

Phone: 414-486-1760

Fax: 414-486-1763

www.manliftengineering.com
sales@manliftengineering.com

T80MH-1500 With Outriggers

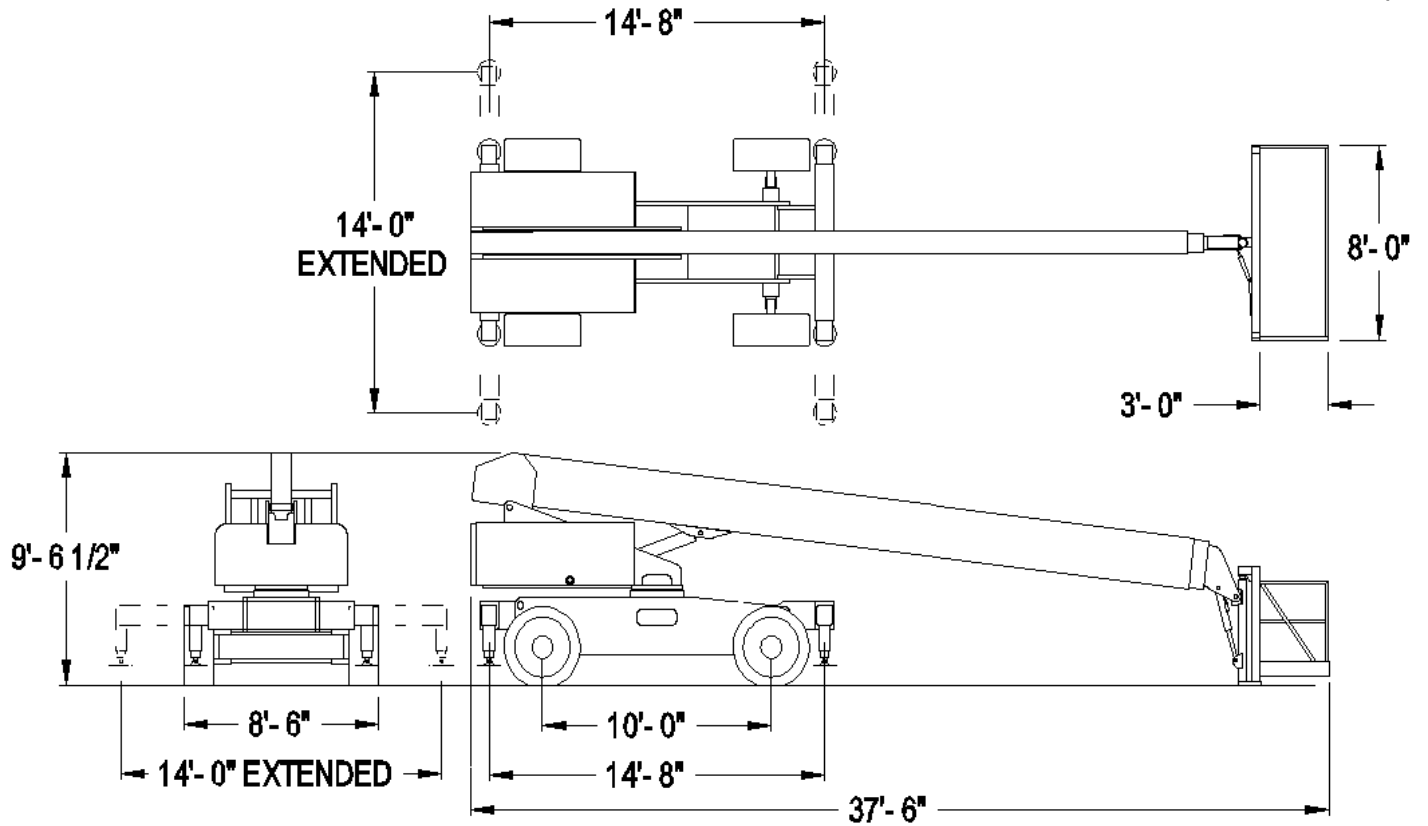

US patents:

- Load Sensing Mechanism #US 7,004,285B2
- Material Handling Device #US 7,182,173B2

MAN & MATERIAL LIFT ENGINEERING

5707 South Pennsylvania Avenue

Cudahy, WI 53110

Phone: 414-486-1760

Fax: 414-486-1763

www.manliftengineering.com
sales@manliftengineering.com