

BATTERY POWERED LIFT

800AJE



Standard Equipment:

- 80 ft 4 in (24.38 m) Platform Height
- Platform Size 36 x 96 in
- Lifting Capacity 500 lbs
- Self Leveling Platform
- (2) - 48 Volt DC Electric Motor
- 750 Amp hr Battery
- On-Board 750 Amp hr Charger
- 6ft Jib (1.83 m) Boom
- Fully Proportional Controls
- 360 Continuous Turntable Rotation
- Tilt Alarm
- Horn

Reach Specifications

Platform Height	80 ft (24.38 m)
Horizontal Reach	51 ft 10 in. (15.8 m)
Up and Over Height	32 ft 1 in. (9.78 m)
Swing	360 Degrees Continuous
Platform Capacity-Restricted	500/1000 lb* (227/454 kg)
Platform Capacity-Unrestricted	500 lb (227 kg)
Platform Rotator	180 Degrees Hydraulic
Jib Length	6 ft (1.83 m)
Jib Range of Articulation	130 Degrees (+70, -60)

Dimensional Data

A. Platform Size	36 x 96 in. (0.91 x 2.44 m)
B. Overall Width	8 ft (2.44 m)
C. Tailswing	2 ft 6 in. (76 cm)
D. Stowed Height	9 ft 10 in. (3.0 m)
E. Stowed Length	36 ft 6 in. (11.13 m)
F. Wheel Base	10 ft (3.05 m)
G. Ground Clearance	12 in. (30 cm)
Weight**	34,300 lb (15,559 kg)
Max. Ground Bearing Pressure	76 psi (5.3 kg/cm ²)

Chassis

Drive Speed	2WD or 4WD
Gradeability	2WD/4WD
Turning Radius, (Inside/Outside)	
2WS	12 ft/22 ft 6 in. (3.66 m/6.86 m)
4WS	7 ft/14 ft 6 in. (2.13 m/4.42 m)
Tires/Type	Pneumatic 445/55D x 19.5

Power Source

48v DC Motor
750 Amp-hr Battery
750 Amp hr Charger

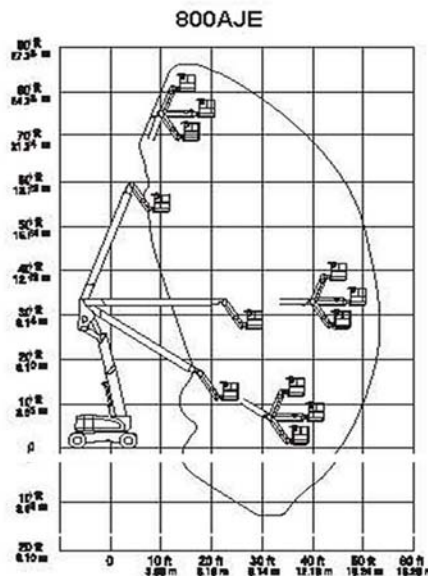
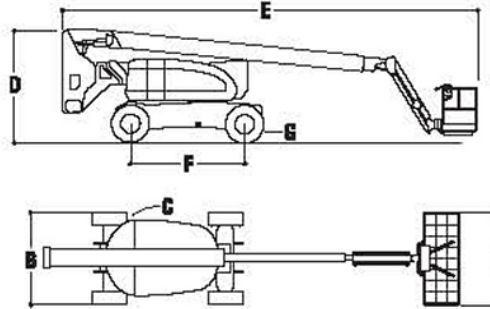

MLE
MAN & MATERIAL LIFT ENGINEERING

5707 S. Pennsylvania Avenue
Cudahy, WI 53110
Phone: 414-486-1760
Fax: 414-486-1763
www.manliftengineering.com
sales@manliftengineering.com