

ATRIUM SPIDER LIFTS

A65TD TRACK DRIVE ATRIUM

The New Standard in Atrium Lifts!



Designed for Casinos, Malls, Airports or Buildings with High Ceilings or Difficult to Reach Windows and Obstructions.

- *Window Cleaning*
- *Painting*
- *Tree Trimming*
- *General Maintenance*

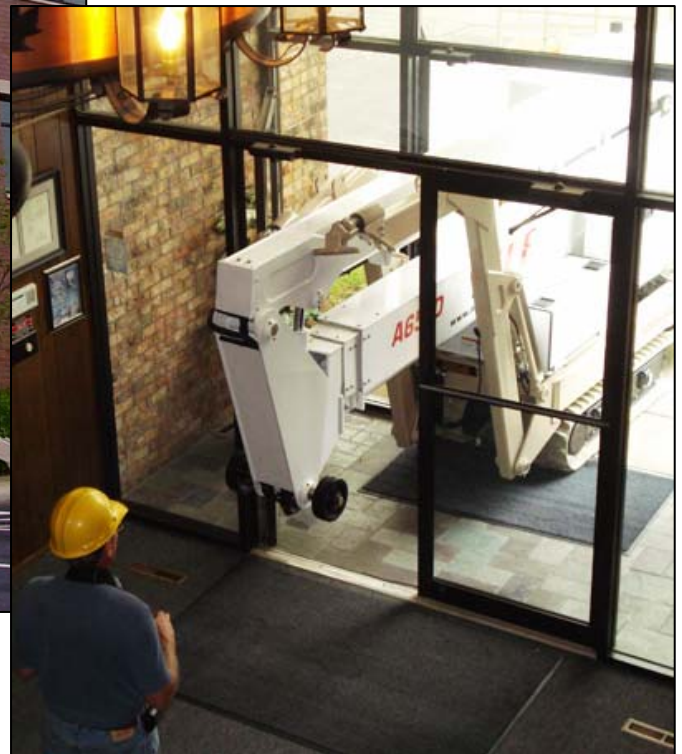

- *71' Working Height*
- *48Volt Battery Powered*
- *Non-Marring Tracks*
- *450/550# Platform Capacity*
- *Fits Though 35" Door*

MLE
MAN & MATERIAL LIFT ENGINEERING
5707 S. Pennsylvania Avenue
Cudahy, WI 53110
Phone: 414-486-1760
Fax: 414-486-1763
www.manliftengineering.com
sales@manliftengineering.com



Information Display at Ground and Platform

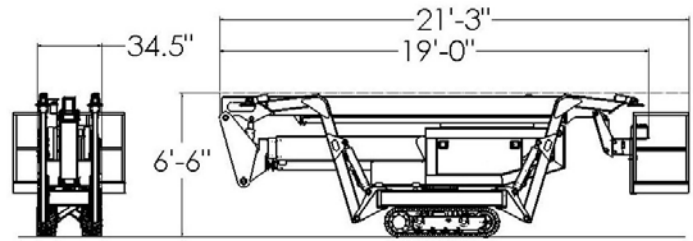

FITS THROUGH SINGLE DOOR!

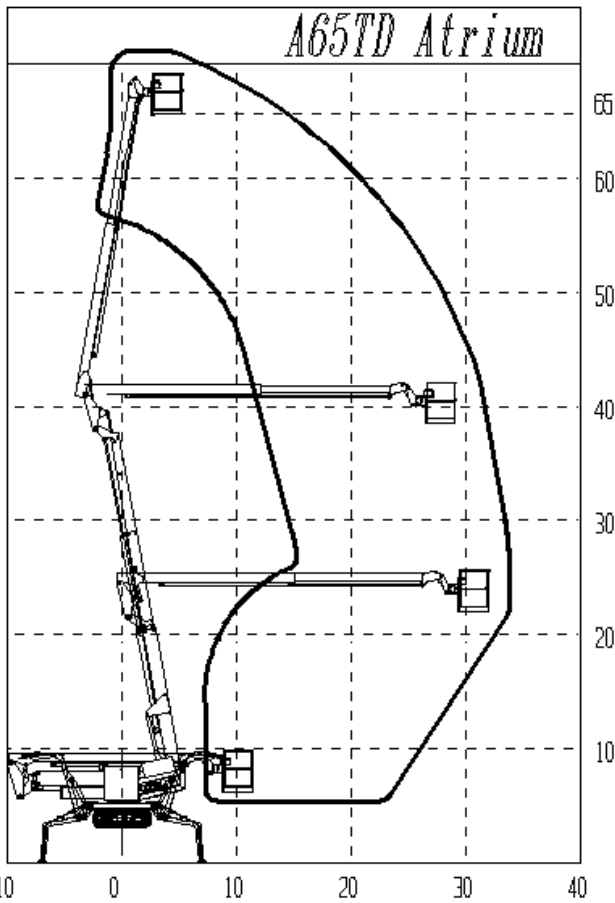
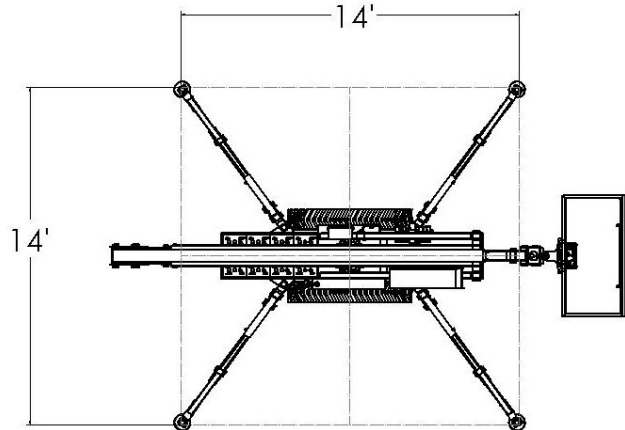

Standard Features

- 3 Foot Outrigger Extension
- 34" Outrigger Clearance
- Automatic Leveling Outriggers
- 48 Volt Long-Life Batteries
- Charging While Operating System

Optional Gas/Diesel Generator with Quick Charge for continuous operation and to provide 120V Power to the Platform

A65TD ATRIUM	U.S.	METRIC
Platform Height	65'	19.81 m
Side Reach	33'	10.06 m
Platform Capacity	450# / 550#	250 kg
Platform Rotation	180°	180°
Grade Capability	48%	48%
Ground Contact Pressure	8 psi	5624 Kg/sq meter
Turret Rotation	360° Non-cont	360° Non-cont
Stowed Length (Platform Removed)	19'	5.8 m
Stowed Width	34.5"	877 mm
Stowed Height	78"	1.98 m
Outrigger Width	14'x14'	4.26 m x 4.26 m
Weight	7300#	3167 kg
Power	48V Battery 275 amp-hr	48V Battery 275 amp-hr
Crane Capability	Yes	Yes

Specifications Subject to Change Without Prior Notice

MLE
 MAN & MATERIAL LIFT ENGINEERING
 5707 S. Pennsylvania Avenue
 Cudahy, WI 53110
 Phone: 414-486-1760
 Fax: 414-486-1763
www.manliftengineering.com
sales@manliftengineering.com